

again, boil vigorously for five minutes or so, and proceed as in the original method.

There are several other points in the method which might be considered further. The time given for passing the air (one-half hour) applies to the case when there is no salt, such as stannous chloride, to be oxidized. This factor will also vary, naturally, with the rapidity of the stream, and will have to be determined for the special conditions of different operators.

In filtering off the arsenious sulphide, time in washing can be saved if the solution is not diluted further than is necessary in washing out the tubes, etc. This keeps more lead chloride in solution, and makes the washing less tedious, particularly if hot water is used throughout.

If the alloy is very high in antimony care must be taken that sufficient tartaric acid is used. The amount necessary has never been carefully determined, but an equivalent of 5 grams is sufficient for ordinary cases (less than 0.1 gram antimony).

If there is considerable excess of lead chloride, so that it crystallizes out to any extent in the antimony solution, it is necessary to use a larger excess of bicarbonate. In this case, also, the end point is not so sharp, although with practice it can readily be determined. The blue color should be permanent for a minute or so, at least.

In oxidizing the arsenious solution 10 cc. of hydrogen peroxide (3 per cent.) is sufficient for all ordinary cases, and the solution must be distinctly alkaline. If this is not the case, shown by separation of sulphur, add a few more drops of sodium hydroxide. It is a good plan also to wash down the sides of the flask before the boiling is finished, as sometimes a little hydrogen peroxide remains undecomposed, and reacts with the potassium iodide.

GEO. M. HOWARD.

PHILADELPHIA, PA., August 31, 1908.

Apparatus for Polarizing at 87°.—Analysts who have to polarize sugar solutions at 87° C. after inversion are familiar with the more or less inconvenient methods or arrangements for obtaining this temperature in the jacketed polariscope tube.

The writer uses the arrangement shown in Fig. 1 and has found it very satisfactory, both for occasional readings as well as for making a number of readings on the same day; it effects a great saving of time. As will be seen from the figure, the polariscope tube and contents are heated by means of an instantaneous water heater. The heater shown can be bought from any dealer in chemical apparatus. In Fig. 1, CW is the cold water supply, G the gas supply. The cold water flows into a copper-tube coil enclosed in HC under which there is a large gauze burner with a pilot light at P. By means of a combination valve, GWV, both the cold

water and the gas are turned on at the same time; the hot water flows into the polariscope tube through HW and then into the waste through WW. T represents the thermometer.

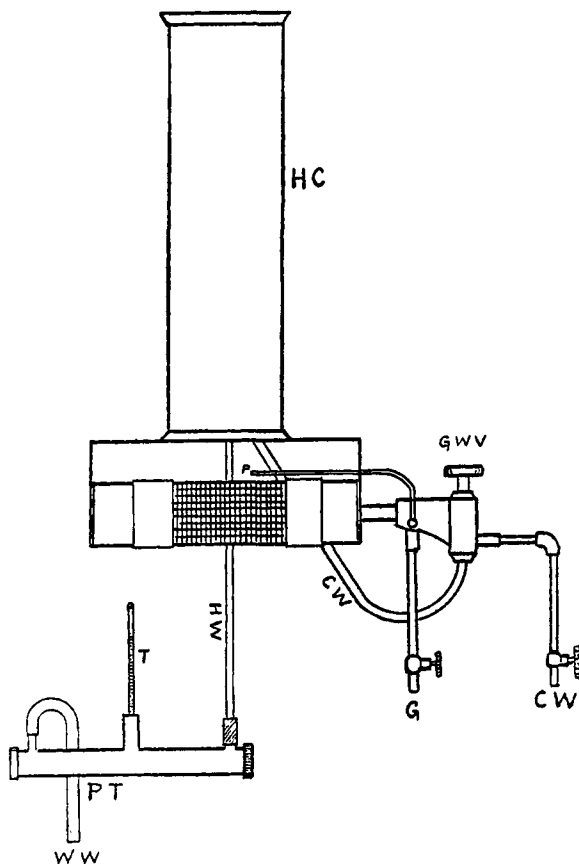

Fig. 1.

The relative amounts of gas and water necessary to heat the solution in the polariscope tube to 87° are regulated by the valves at G and CW; this requires some experience, especially when the water is quite cold. It has been found that this arrangement can be still further improved by having a second valve just below G which may be used for shutting off most of the gas when the valve GWV is turned on; this allows the cold water to flow through the heating coil and prevents formation of steam, which sometimes happens if both gas and water are turned on when the coil is filled with hot water from a previous run. The connection between the heater and the polariscope should be made with rubber tubing so as to allow agitation of the sugar solution.

ALBERT P. SY.